

ACUTE ANGLE INTERSECTION

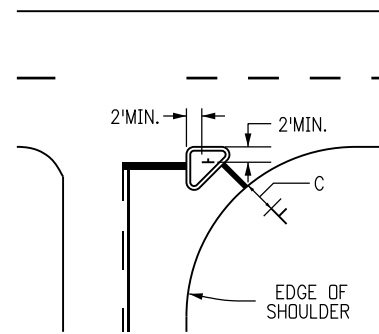

CHANNELIZED INTERSECTION

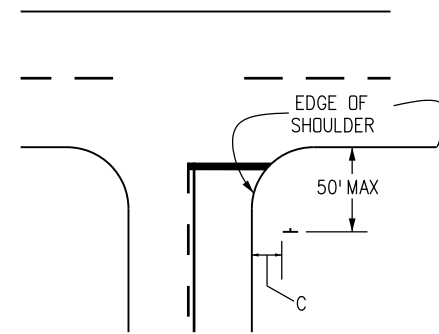

WIDE THROAT INTERSECTION

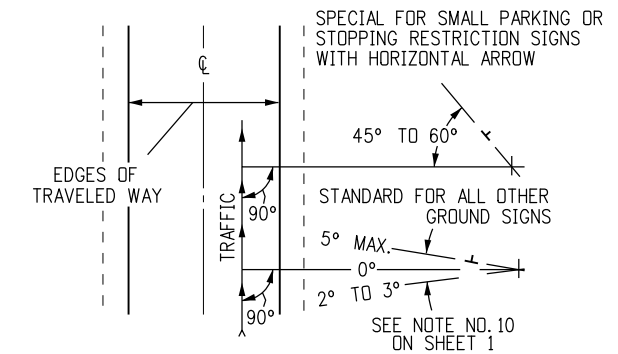

NORMAL ANGULAR PLACEMENT IS 0°. SIGNS CLOSER THAN 30 FT. SHOULD BE TURNED SLIGHTLY AWAY TO MINIMIZE SPECULAR REFLECTION. SIGNS PLACED 30' OR MORE SHOULD GENERALLY BE TURNED TOWARD THE ROAD.

ANGULAR PLACEMENT

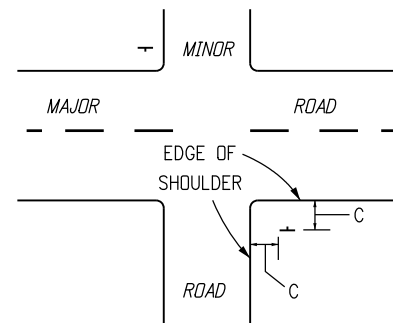

MINOR CROSSROAD

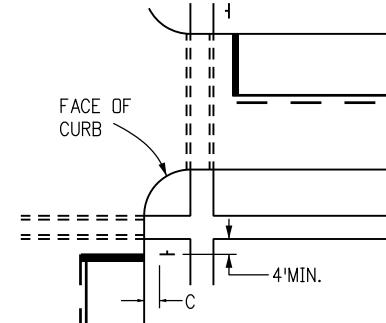

URBAN INTERSECTION

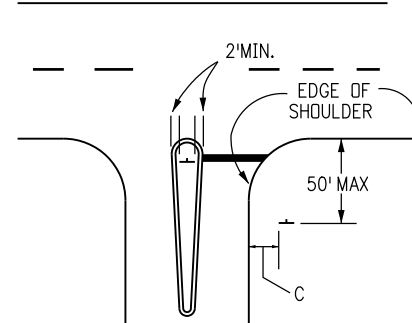

DIVISIONAL ISLAND

TYPICAL LOCATIONS-STOP SIGNS AND YIELD SIGNS

PLACEMENT TABLES

LATERAL PLACEMENT			VERTICAL PLACEMENT (MINIMUM) (9' MAXIMUM)			
KEY	ALL CLASSES OF STREETS AND HIGHWAYS		KEY	FREEWAYS AND EXPRESSWAYS	CONVENTIONAL STREETS AND HIGHWAYS	
	MINIMUM	NORMAL			URBAN	RURAL
*A	2'-0" & NOTE NO.4	15'-0" PLUS CURB OR SHOULDER WIDTH	D	7'-0" OR NOTE NO. 10	7'-0"	5'-0"
*B	2'-0" & NOTE NO.4	30'-0" OR MORE INCLUDES CURB OR SHOULDER	E	6'-0"	7'-0"	5'-0"
*C	2'-0" & NOTE NO.4	6'-0" PLUS CURB OR SHOULDER WIDTH OR IF NONE 15'-0"	F	8'-0" OR NOTE NO. 10	7'-0"	5'-0"
			G	6'-0"	6'-0"	4'-0"
			H	5'-0"	6'-0"	4'-0"

* SEE NOTE NO. 6 ON SHEET 1

Computer File Information	
Creation Date: 07/04/12	Initials: KCM
Last Modification Date:	Initials:
Full Path: www.coloradodot.info/library/traffic/traffic-s-standard-plans	
Drawing File Name: S-614-01_2of2.dgn	
CAD Ver.: MicroStation V8 Scale: Not to Scale Units: English	

Sheet Revisions	
Date:	Comments
(R-X)	
(R-X)	
(R-X)	
(R-X)	

Colorado Department of Transportation
 4201 East Arkansas Avenue
 Denver, Colorado 80222
 Phone: (303) 757-9543
 Fax: (303) 757-9219
 Safety & Traffic Engineering Branch KCM/KEN

GROUND SIGN PLACEMENT
 Issued By: Safety & Traffic Engineering Branch July 4, 2012

STANDARD PLAN NO.
 S-614-1
 Sheet No. 2 of 2